



# MATERIAL POLITICS construction system for low-income settlements

The project, funded by the National Research Council of Ecuador and the Economic and Social Research Council in Britain, developed an integrated construction system to transform and empower everyday practices in the deprived settlement of Monte Sinaí, in Ecuador. With the aim of harnessing and redistributing the value stemming from building practices in the neighbourhood, the system fosters the community's involvement in the industrialisation of standardised bamboo panels. These serve as the basic components of a construction language that enables local dwellers to disseminate a series of adaptable architectural and infrastructural typologies to support dwelling, commercial and productive programs.

From easy-to-assemble, modular housing units to platforms for social engagement, exchange and circulation, the research relied on innovative participatory and action based methodologies to detect existing technical skills, understand the networks of provision of building materials and minimise environmental impacts. Working in conjunction with local activists and neighbours, the Ministry of Urban Development and Housing and NGOs, the project presented an alternative vision for the urbanisation of peripheral settlements: one that finds in the socialisation of a construction system a means to materialise and imagine a more egalitarian and just urban life.



SOUTH AMERICA  
pop. 387,000,000 approx



ECUADOR  
pop. 15,300,000 approx



GUAYAQUIL  
pop. 2,700,000 approx



MONTE SINAÍ  
pop. 150,000 approx

## MATERIAL POLITICS TEAM

- Leandro Minuchin
- Aida Rodriguez-Vega
- Ellie Shouer
- Patrick Cronin
- Konrad Koltun
- Joseph Smith
- Eira Capelan



TYPICAL STREET  
Bamboo and concrete houses



MICRO-ENTERPRISES  
Local production of wares



A TYPICAL DWELLING  
Bamboo structure and panelling



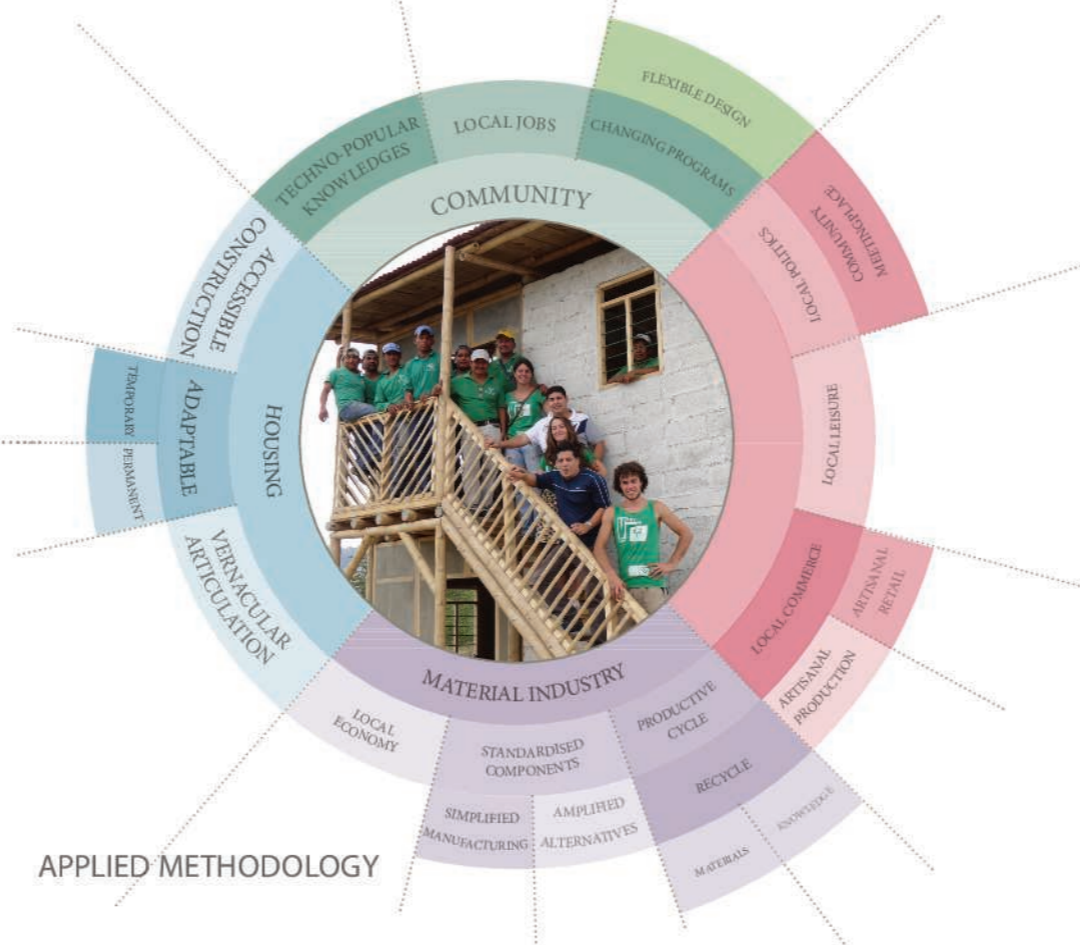
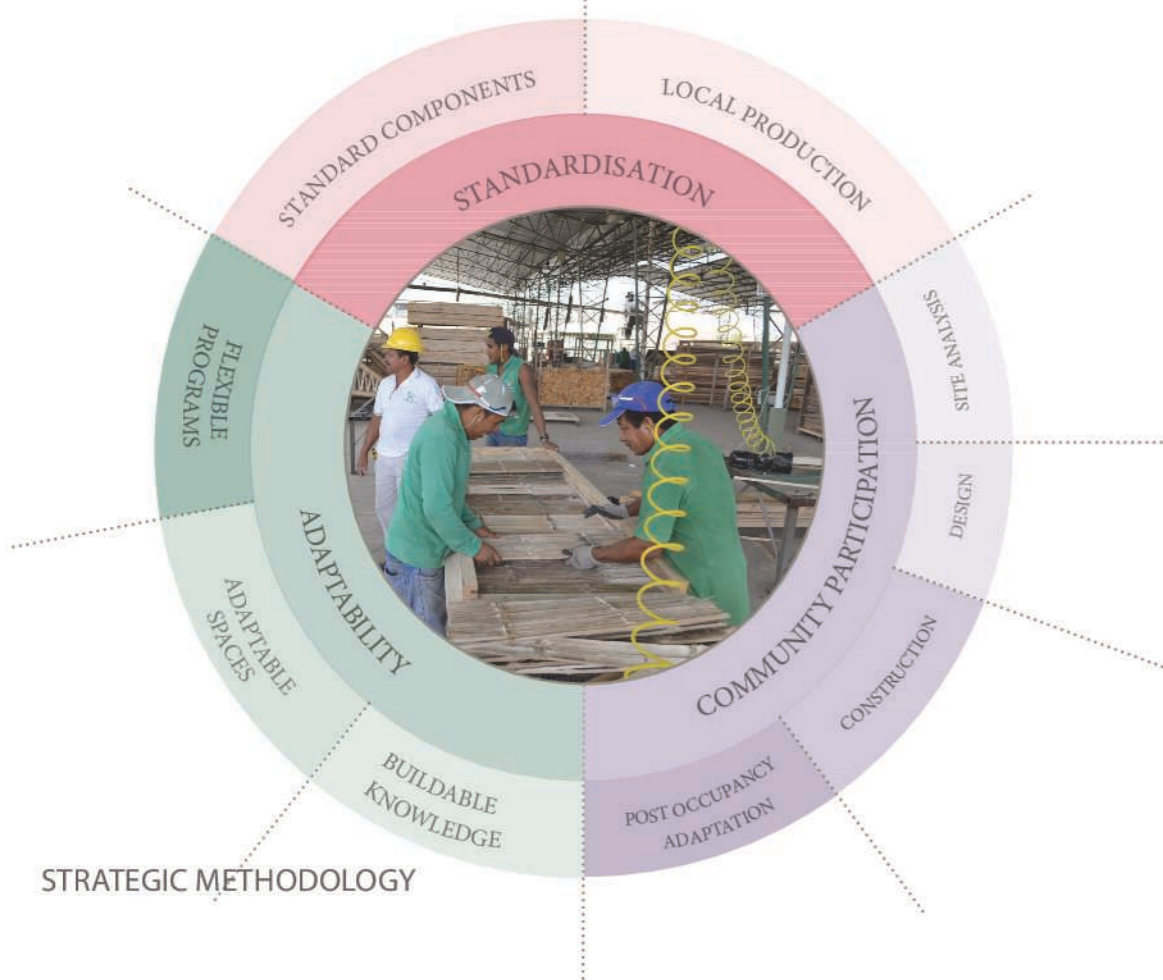

“Share knowledge, promote discussion, reflection and awareness, and collaborate in the advancement of the social production of habitat”

The ongoing active research project in Monte Sinai entangles design, construction and local technical knowledge into a unique platform for participation and community involvement. The aim of the intervention was to co-produce a construction system that would allow local dwellers to build and manipulate the physical supports needed to carry out their everyday activities.

To this end, the project first employed a series of methodological tactics to capture the way residents have socially and politically engaged with the territory, to register the adaptations they have made to their dwellings, to accommodate multiple programs and to map the incremental upgrades made to their homes and plots of land. This jointly-produced body of research directly informed the initial design for the housing unit, helping to identify local material networks, the relationships between different actors (both individuals and organisations), and labour availability.

The outcome of this collaborative process is a construction system that enables residents to adapt their physical surroundings according to their needs and desires. The initiative equips the community with a set of architectural tools that allows them to control and participate in the construction process that shapes their neighbourhood.

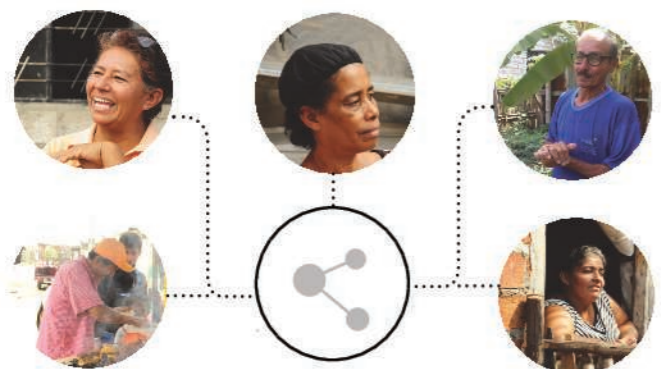

SHARING KNOWLEDGES

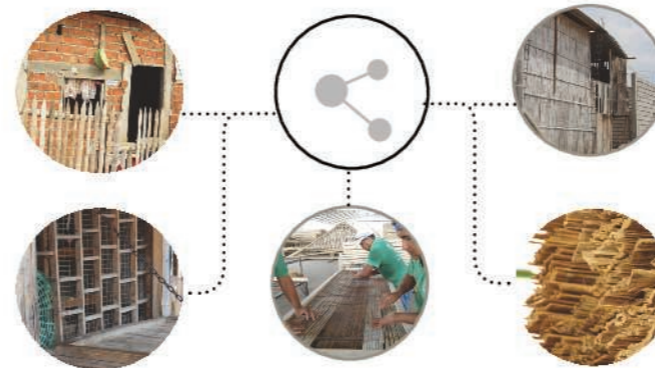

1:1 BUILT ADAPTATIONS

While many more housing units are under development, the construction of three 1:1 prototypes became fundamental to understanding both technical and social implications of the system and its potential for adaptability.

1

INITIAL PROTOTYPE

Served to develop and exchange ideas regarding constructive detailing of the housing unit together with builders and neighbours of Monte Sinai



2

PRODUCTIVE PROTOTYPE

Served to explore how the constructive system may adapt into a productive house with possibilities for micro-cultivation of vegetables and tilapias.



3

COMMUNITY PROTOTYPE

Developed as a community space, in close conjunction with prospective occupants of future units in order to explore floor plan alternatives and exemplify adaptability to the neighbours.





“Facilitate the use of appropriate technologies, materials and labour adequate to local values, to the cultural specificity and responsive to the natural environment;”



Image illustrating the unit being adapted for commercial and productive use at ground level.

The construction system was assembled around the recuperation and inclusion of local materials and local technical knowledges. As an adaptable and productive housing typology, the housing unit unfolds through the combination of standardised bamboo panels and the application of local building and constructive techniques that are reproduced through self-build experiments. Bamboo is a local material that has been manipulated and used in the region for centuries.

The decision to incorporate bamboo—a construction material that carries a social stigma in Ecuador—into the design of the housing unit is one example of how the design process sought to reconcile environmental, social and economic issues. By proposing a concrete block core from which a range of formations of bamboo supports and panels could be constructed to create enclosures and platforms for different domestic uses, the housing unit seeks to demonstrate bamboo’s utility in application with other materials. By foregrounding bamboo as a material with strong internal environmental regulation properties, aesthetic value, and geographic and financial accessibility, the housing unit aims to erode bamboo’s connotations of poverty and structural inadequacy.

Understanding the site



Mapping the existing urban fabric and registering local technologies



Understanding existing methods of production

Sustainable materiality



Promoting the use of local sustainable materials



Promoting passive cooling techniques

Buildability & adaptability



Developing standardised components

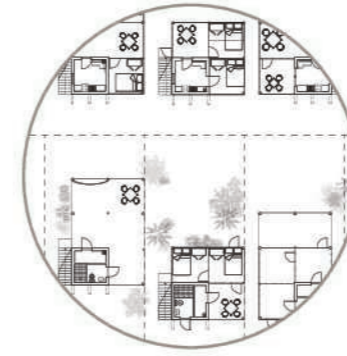

Using existing technical knowledges to explore adaptable floor plans



Developing prototypes together with local experienced builders

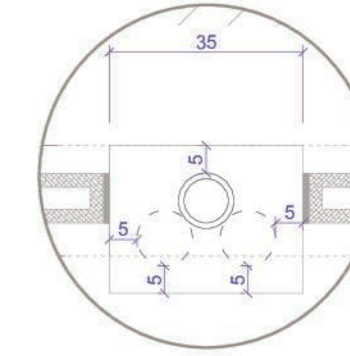

Allowing for self expansion and use adaptability





Images of the model as a communication tool with the community involved in the programme.

## “Support participatory, democratic, multicultural and interdisciplinary processes and approaches in strengthening community solidarity as a factor of rural and urban social development”



The model being presented to the community.

This project looks into the promotion and enhancement of social production of habitat through a process of community inclusion, use of popular technical knowledge, and the local production of materials and construction techniques. Through the application of these parameters, a construction system is developed which aims to not only respond to local everyday and future needs, but to act as a platform of investigation and further experimentation. By the direct involvement of the community during fieldwork, development, proposal and realisation, the project promotes discussion and establishes awareness about the community within itself, and between the community and external bodies and organisations such as local NGOs, the Ministry of Housing and so on; a fact which ultimately leads to an increased sense of control of the locals over their own built environment.

In order to socialise the benefits of the bamboo construction system, we combined the experience of walking through 1:1 prototypes of the housing unit with a 1:50 construction model.

The 1:50 model, which comprised all of the component parts of the housing unit, allowed members of the community to understand the scope of adaptability and expandability of the typology giving the residents the opportunity to provide feedback as to how the design could be altered to better respond to their practical domestic needs.

### D - TECHO

Terminar la maqueta colocando la lámina del techo, encajando las lengüetas de la estructura en los orificios de la lámina (DA).

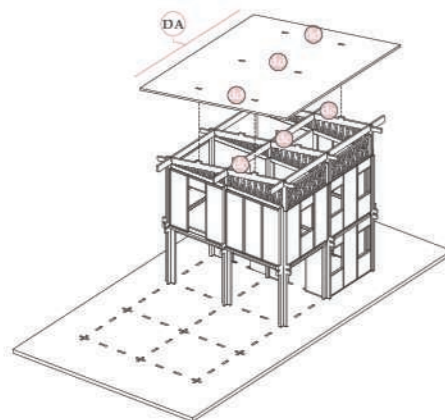

### ... - EXTENSIÓN

En caso de desear expandir la casa de 2x2 módulos a una de 2x3, simplemente añadir otra escuadra estructural, agregar los paneles de suelo y pared deseados y sustituir el techo (estructura y lámina) por la opción más grande.

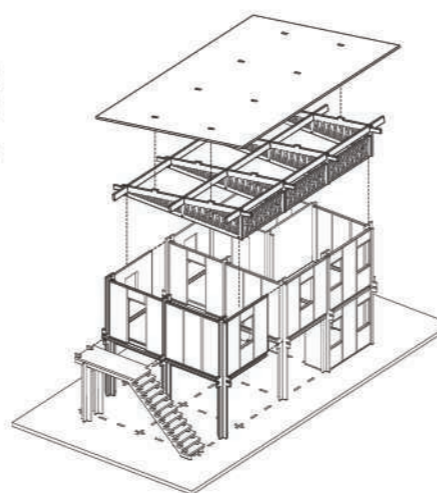

### E - ESCALERA

Colocar la escalera de acuerdo a preferencia personal. Encajar la plataforma del descanso de la escalera en los nichos de las columnas.

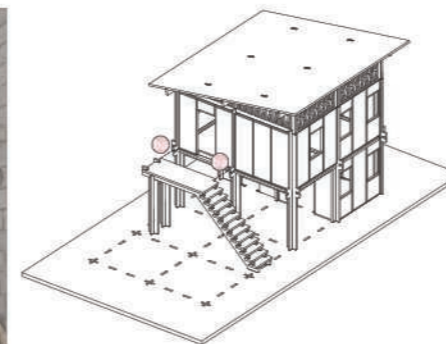

### D - TECHO

Colocar la estructura del techo encajando los nichos de la misma en los nichos de las columnas.

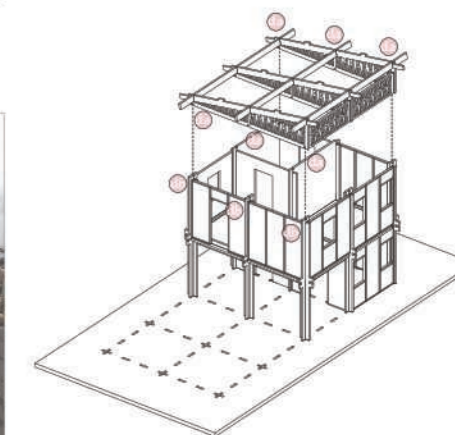

Pages from the manual used to explain both the construction and expandability of the SUYA.